

The key control size with the "▲" symbol

REV	DESCRIPTION	SIGNATURE	DATE
AO	ORIGIN	Fang Shi Lan	2023.01.30

TABLE A

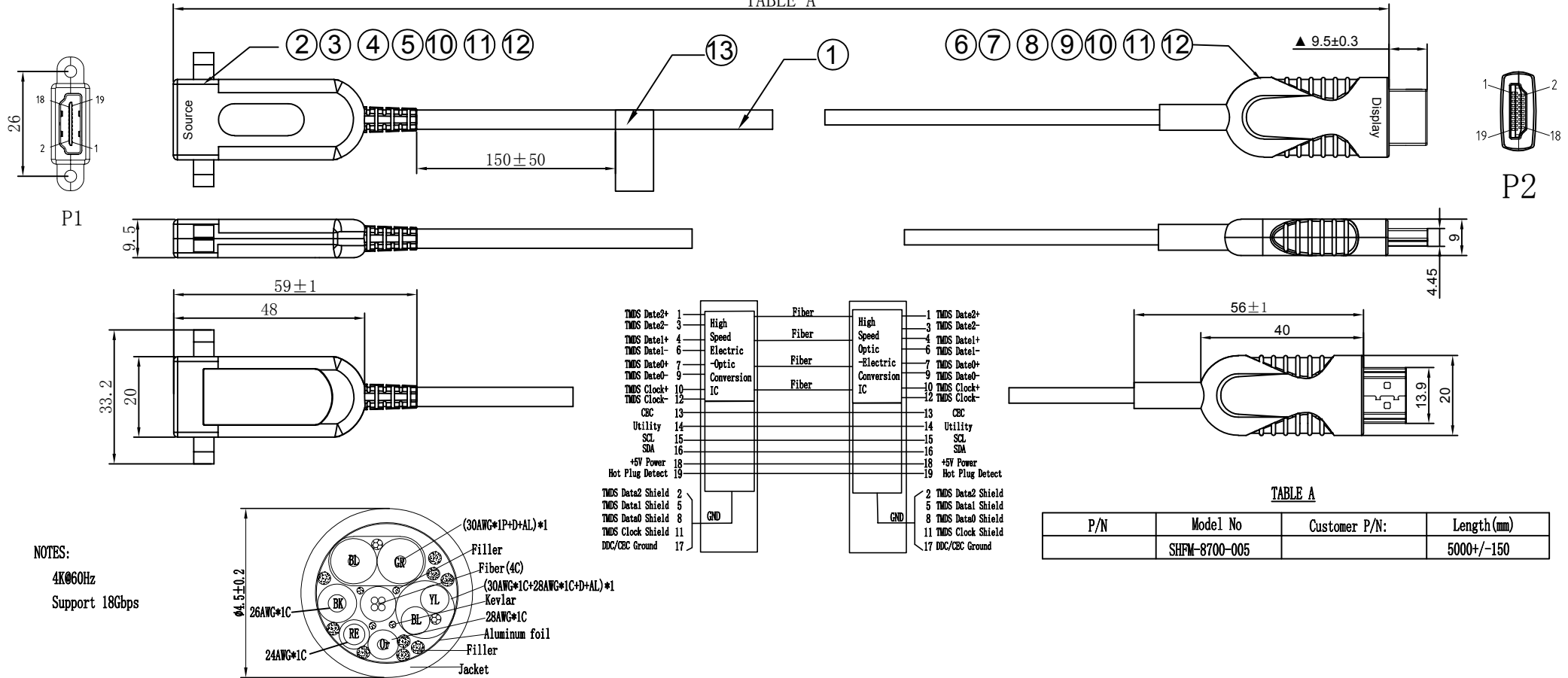

NOTES:  
4K@60Hz  
Support 18Gbps

TMD5 Data2+	1	Fiber	High Speed	1	TMD5 Data2+
TMD5 Data2-	3	Fiber	Speed	3	TMD5 Data2-
TMD5 Data1+	4	Electric	Optic	4	TMD5 Data1+
TMD5 Data1-	6	-Electric	-Electric	6	TMD5 Data1-
TMD5 Data0+	7	-Optic	-Optic	7	TMD5 Data0+
TMD5 Data0-	9	Conversion	Conversion	9	TMD5 Data0-
TMD5 Clock+	10	IC	IC	10	TMD5 Clock+
TMD5 Clock-	12			12	TMD5 Clock-
CBC	13			13	CBC
Utility	14			14	Utility
SCL	15			15	SCL
SDA	16			16	SDA
+5V Power	18			18	+5V Power
Hot Plug Detect	19			19	Hot Plug Detect
TMD5 Data2 Shield	2			2	TMD5 Data2 Shield
TMD5 Data1 Shield	5			5	TMD5 Data1 Shield
TMD5 Data0 Shield	8			8	TMD5 Data0 Shield
TMD5 Clock Shield	11			11	TMD5 Clock Shield
DDC/CBC Ground	17			17	DDC/CBC Ground

P/N	Model No	Customer P/N:	Length(mm)
	SHPM-8700-005		5000+/-150

13	QR Code	1	PCS
12	SR Black	2	PCS
11	Screw	4	PCS
10	Clip	2	PCS
9	HDMI A male shell (Display) Matte Black (Display)	1	PCS
8	HDMI A male shell (Display) Matte Black (Display)	1	PCS
7	HDMI A PCBA (Display)	1	PCS
6	HDMI A male Plug Gold-Plated	1	PCS
5	HDMI A Female Shell (Upper) Matte Black (Source)	1	PCS
4	HDMI A Female Shell (Bottom) Matte Black (Source)	1	PCS
3	HDMI A Female PCBA	1	PCS
2	HDMI A Female connector	1	PCS
1	HDMI Active Optical Cable (4 Fiber+7 Copper wire) Black PVC OD: 4.5±0.20mm	TABLE A	mm
ITEM	SPECIFICATIONS		Q'TY UNIT

TOLERANCES UNLESS OTHERWISE STATED	
X.	= ± 1
X.X	= ± 0.25
X.XX	= ± 0.1
TOOLING	
DECIMALS ANGLES	
X.	± 0.3 ± 1°
X.X	± 0.2 ± 0.5°
X.XX	± 0.1 ± 0.5°

**E-Like Industrial (Hong Kong) Limited**

TYPE: HDMI 2.0 Female to Male Active Optical Cable

DRAW:	PART NO: SHFM-8700-xxx-LHX036-H122
CKD:	CUSTOMER: UNIT:mm
APP:	DWG NO: 81-06369 REV:AO
SHEET: 1/1	DATE: 2023.02.01